

# Yale® Tri-Pack 50 Series

Non Handed Door Closer

## Installation Instructions

80-9350-2502-010 (12-09)

## Non Hold Open Models

Sized (Sizes 2,3,4,5,6) Adjustable (Sizes 3 thru 6)

Weaker  
↓  
Stronger  
+

**52BC**  
**53BC**  
**54BC**  
**55BC**  
**56BC**

**51**  
  
**51BF**  

**CAUTION** An Incorrectly installed or improperly adjusted door closer can cause property damage or personal injury. These installation instructions should be followed to avoid the possibility of misapplication or misadjustment. **CAUTION**



"DL" suffix (Delayed Action) is an optional feature. A separate sheet is supplied showing closer adjustments.

**NOTE:** For special applications a separate door and frame preparation template is packed with these instructions. Use this instruction sheet for installation sequence and closer adjustments only.

- Doors should be hung on ball bearing or anti-friction hinges.
- A separate door stop is recommended.
- Door and frame must be properly reinforced.
- Adjust closing time speed between 3 and 7 seconds from 90° to 0°.
- These door closers should NOT be installed on the exposed side (weather side) of exterior doors.

**Regular Arm Installation**  
See Page 2

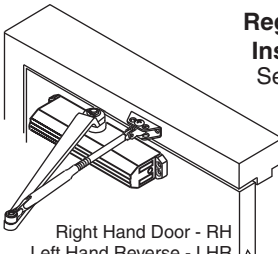

Right Hand Door - RH  
Left Hand Reverse - LHR

**Top Jamb Installation**  
See Page 5

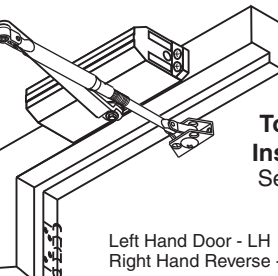

Left Hand Door - LH  
Right Hand Reverse - RHR

**Parallel Arm Installation**  
See Pages 3 & 4

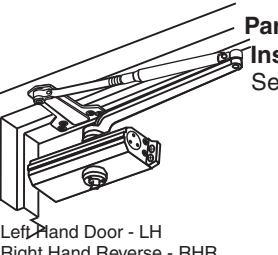

Left Hand Door - LH  
Right Hand Reverse - RHR

**Regular Arm Installation**  
See Page 2

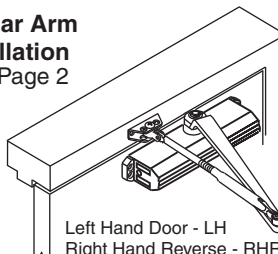

Left Hand Door - LH  
Right Hand Reverse - RHR

**Top Jamb Installation**  
See Page 5

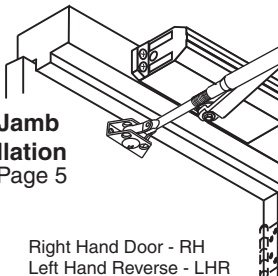

Right Hand Door - RH  
Left Hand Reverse - LHR

**Parallel Arm Installation**  
See Pages 3 & 4

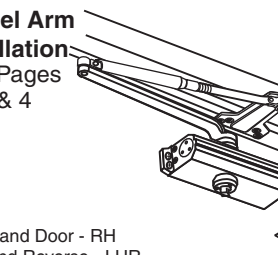

Right Hand Door - RH  
Left Hand Reverse - LHR

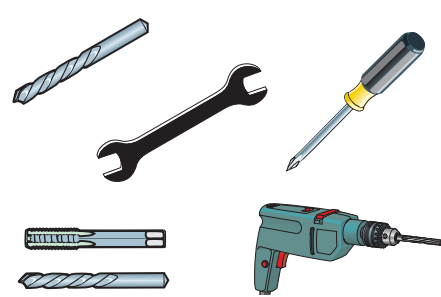
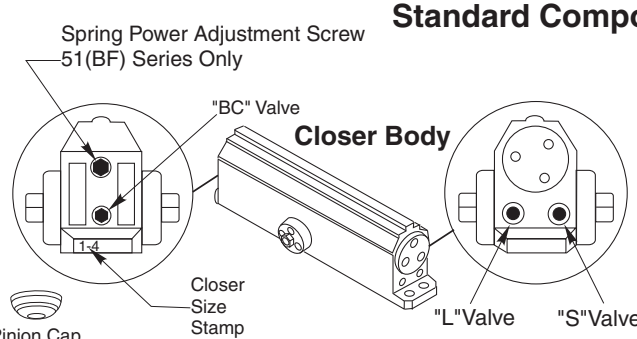
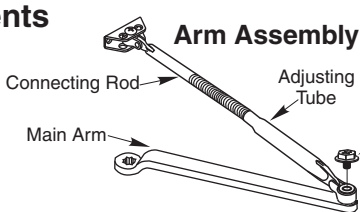
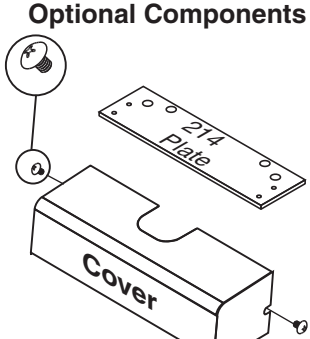
	<p><b>Self Drilling Screws</b> Wood and Metal</p> <p>For Wood drill 3/16 hole</p> <p><b>Machine Screws</b> #7 Drill, 1/4-20 Tap</p>	<p><b>(Optional)</b> Sleeve Nut and Bolt</p> <p>Drill 9/32 thru from Closer Side 3/8 Drill other side</p> <p><b>Thru Bolt and Grommet Nut</b></p> <p>Drill 9/32 thru from Closer Side 3/8 Drill other Side</p>
<p><b>Standard Components</b></p> 	<p><b>Arm Assembly</b></p>  <p><b>Soffit Plate</b> 289A Soffit Plate Used with Parallel Arm Closers Only</p>	<p><b>Optional Components</b></p> 

# 50 Series

## Non Hold Open Door Closers — Regular Arm

80-9350-2502-010 (12-09)

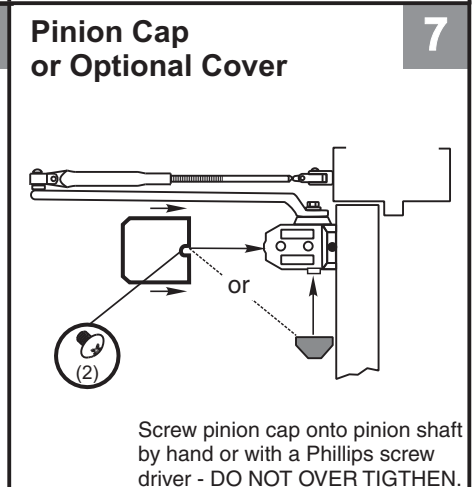
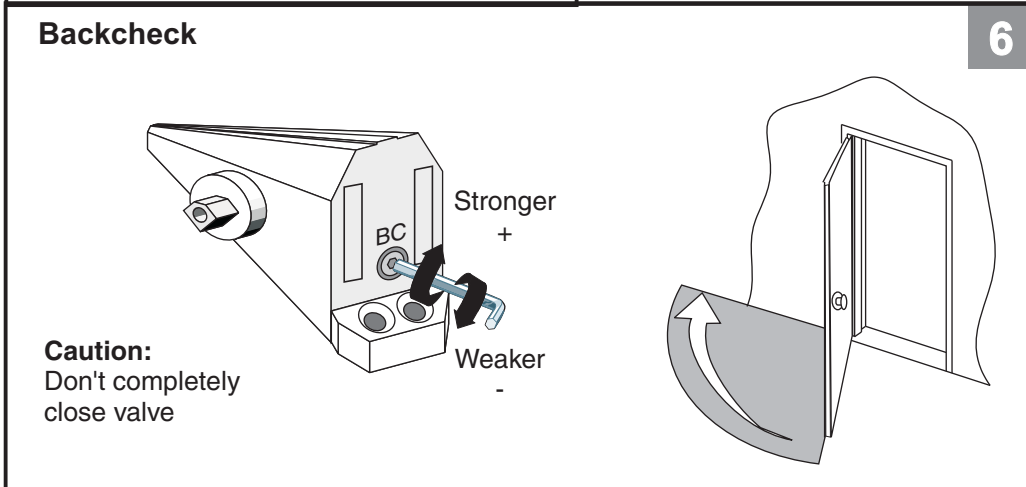
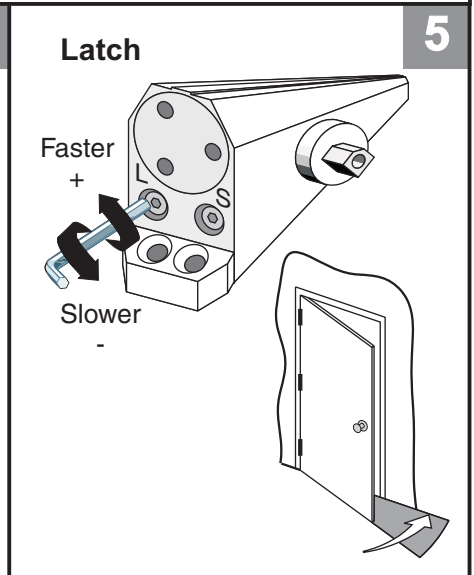
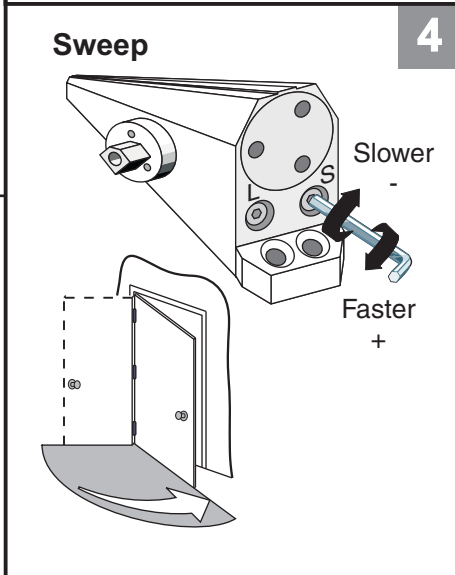
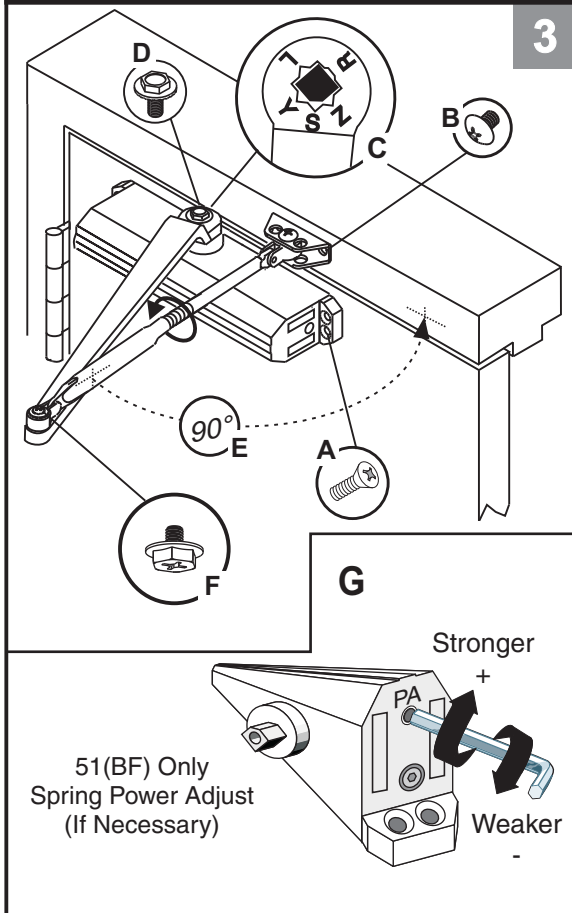
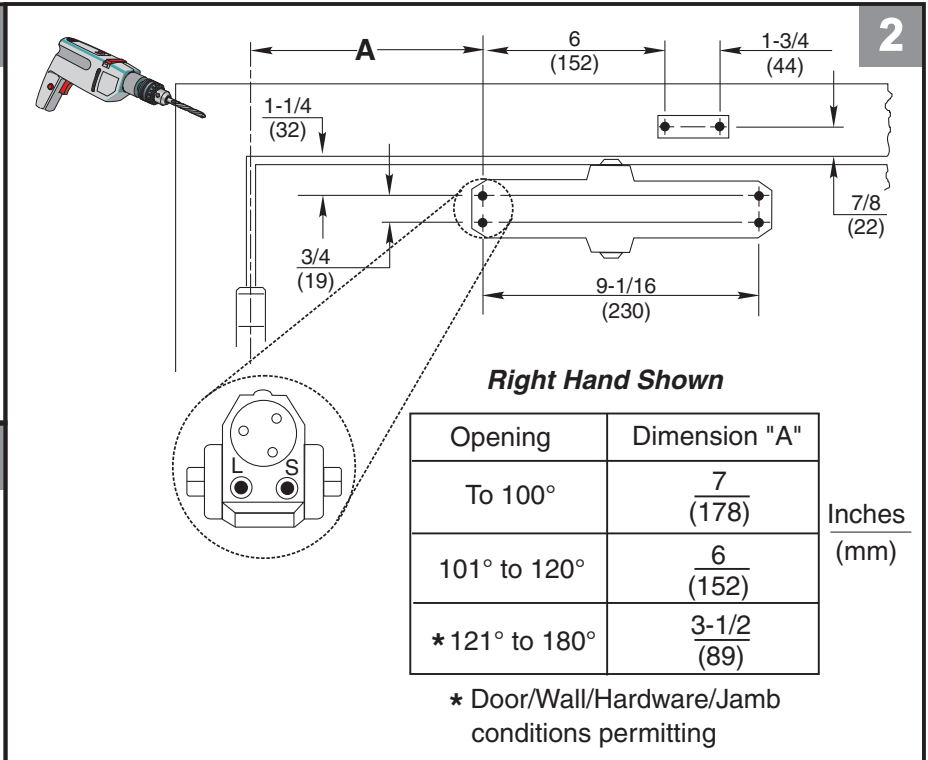
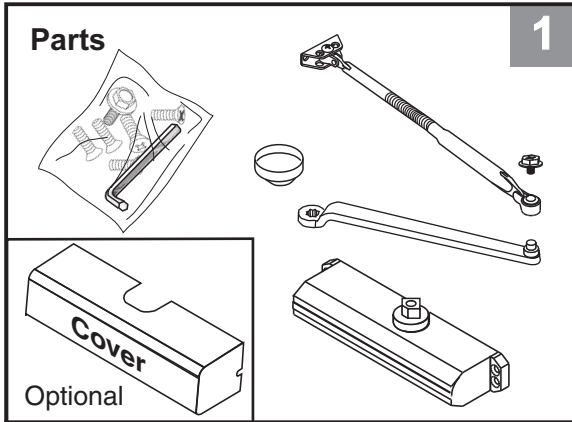

# 50 Series

## Non Hold Open Door Closers — Parallel Arm

80-9350-2502-010 (12-09)

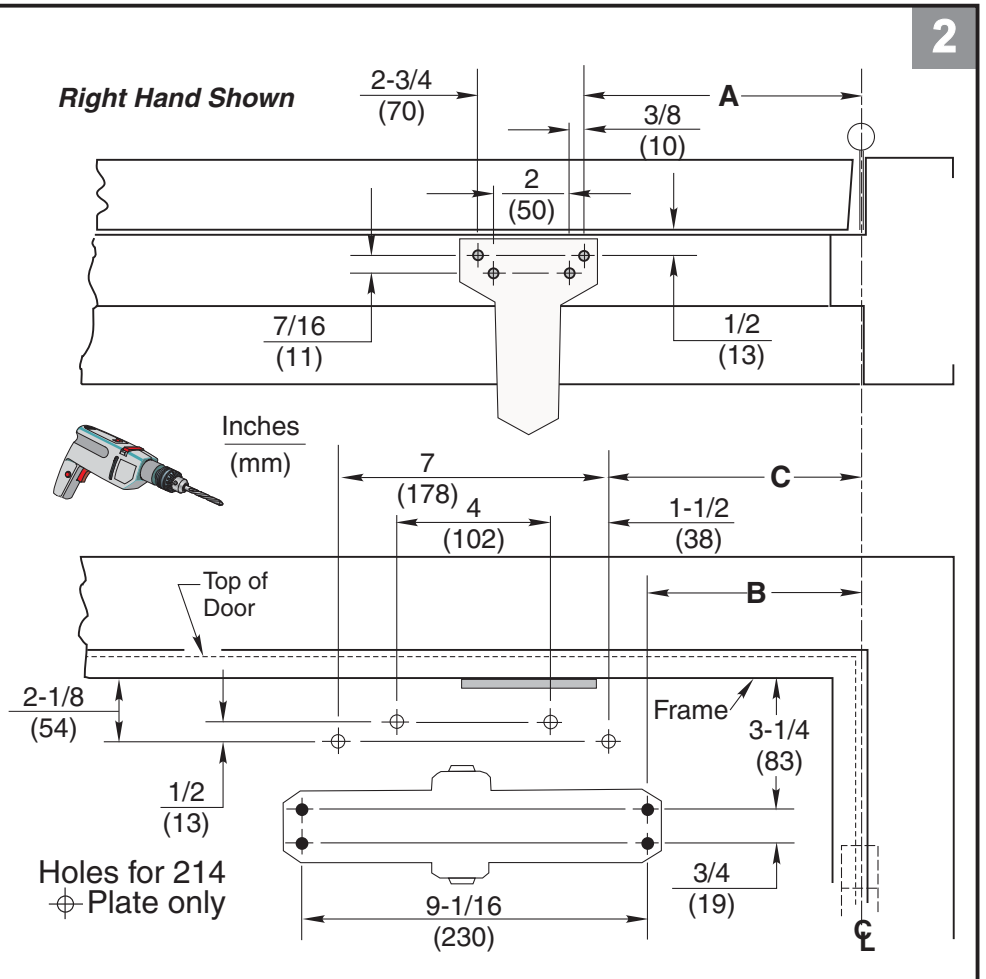
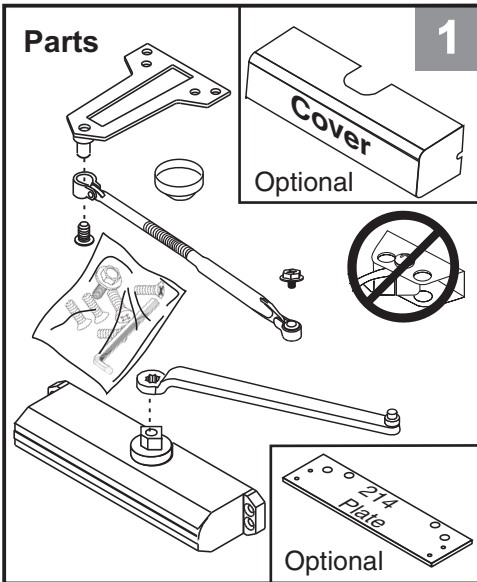

Door Opening	A	B	C
To 100°	9-1/4 (235)	7-5/8 (194)	8-5/8 (219)
101° to 130°	7-3/4 (197)	6-1/8 (156)	7-1/8 (181)
*131° to 180°	5-3/4 (146)	4-1/8 (105)	5-1/8 (130)

\* Door/Wall/Hardware/Jamb conditions permitting

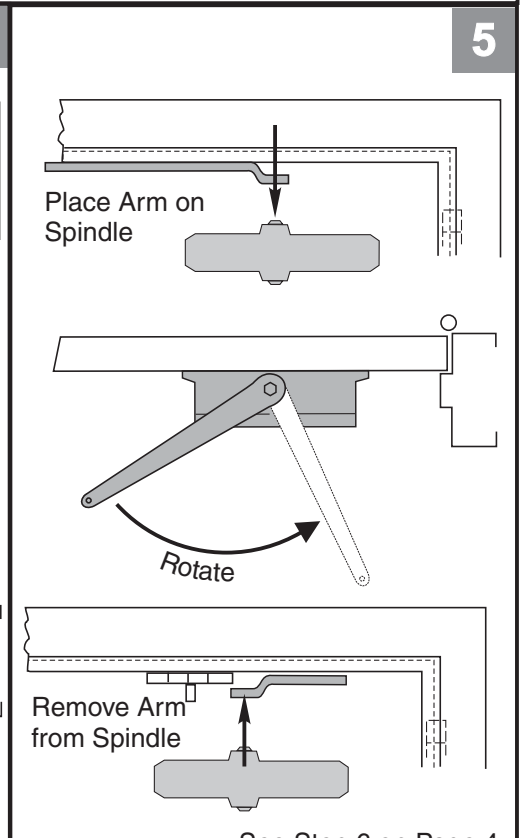
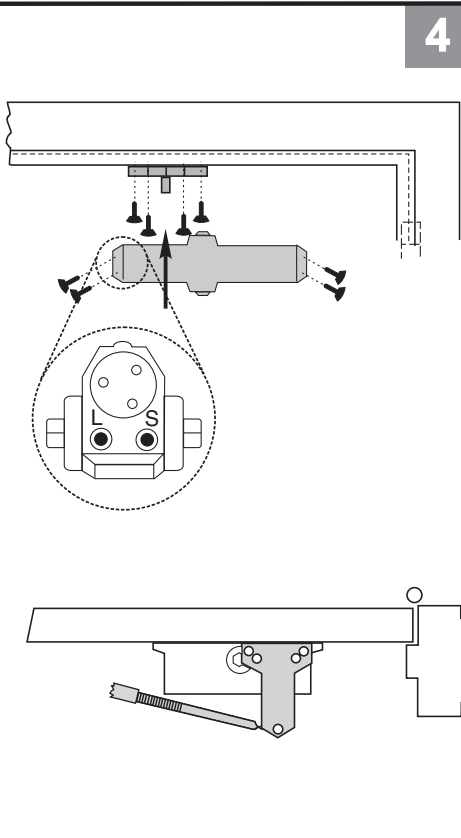
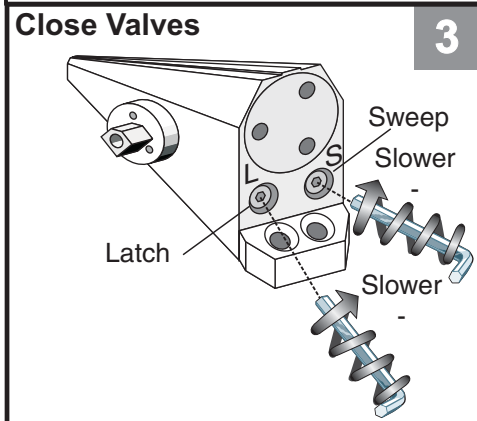

See Step 6 on Page 4

# 50 Series

## Non Hold Open Door Closers — Parallel Arm

80-9350-2502-010 (12-09)

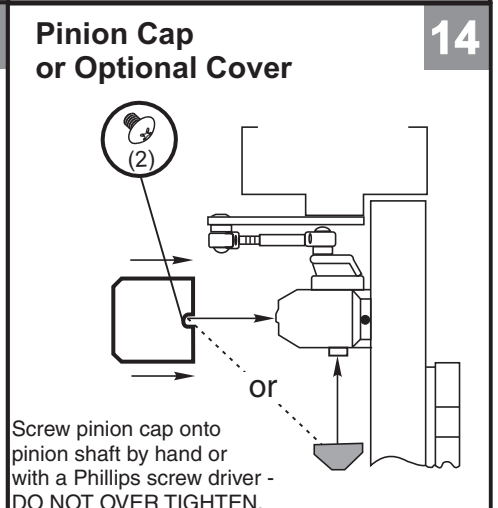
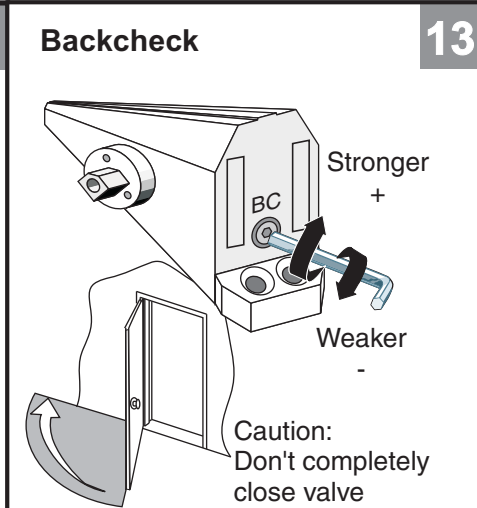
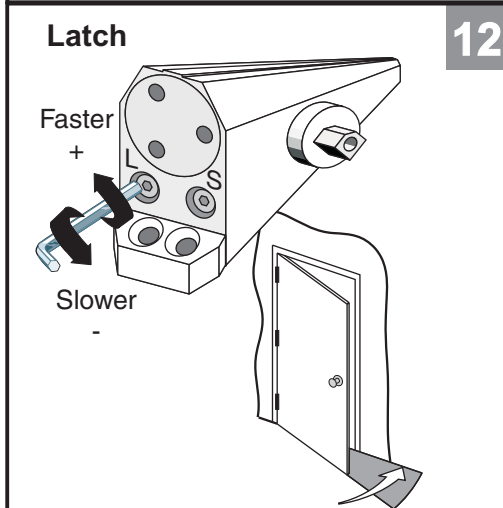
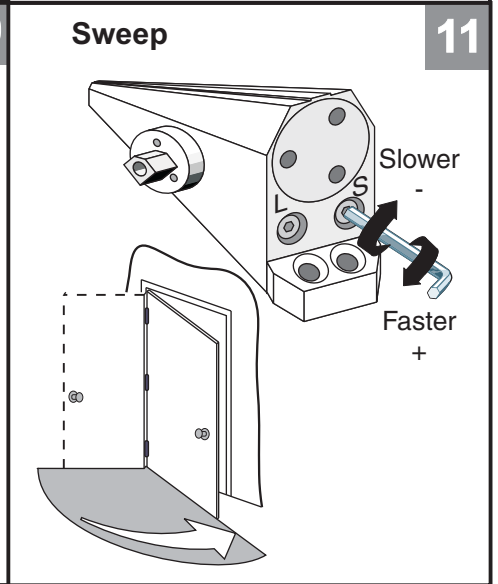
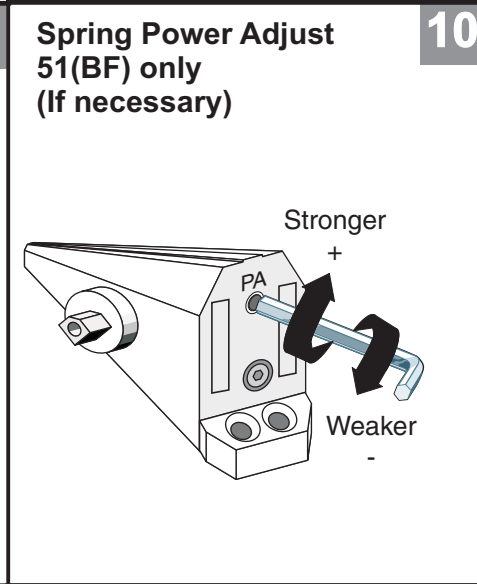
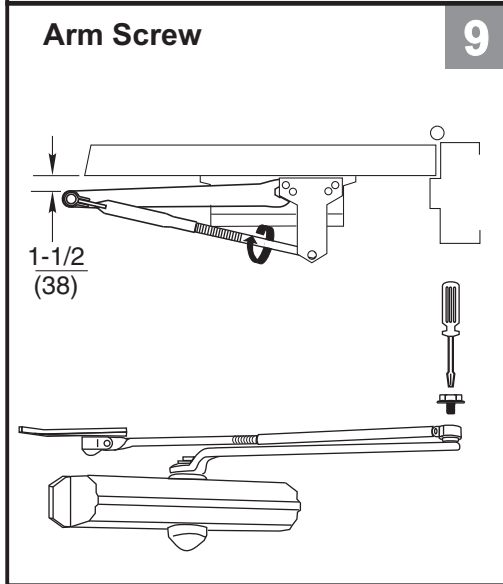
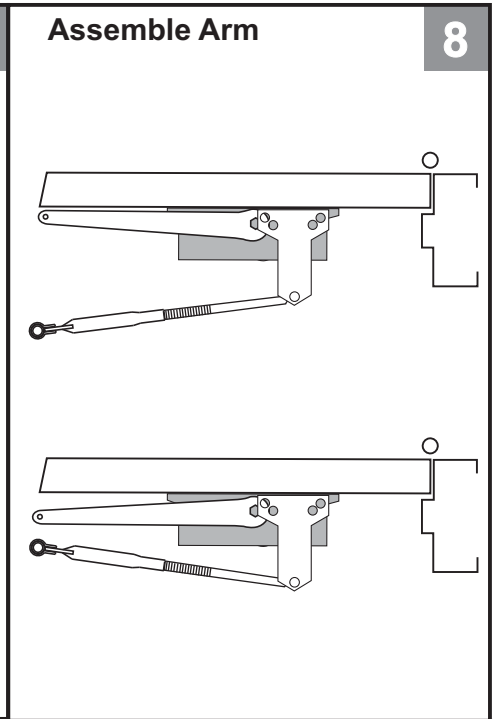
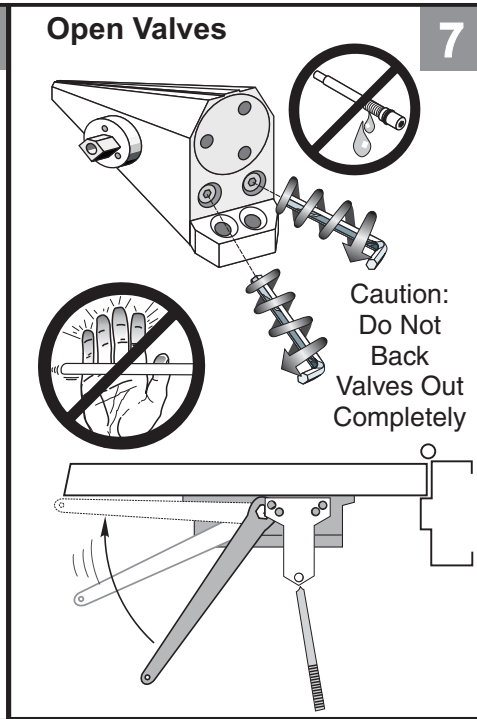
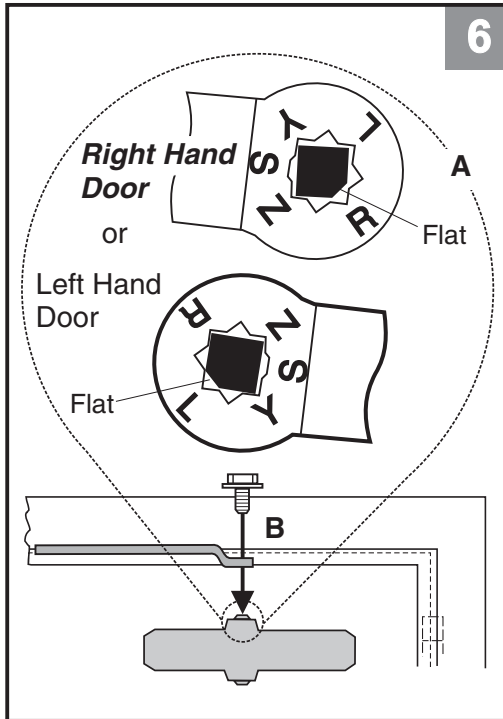

# 50 Series

## Non Hold Open Door Closers — Top Jamb Arm

80-9350-2502-010 (12-09)

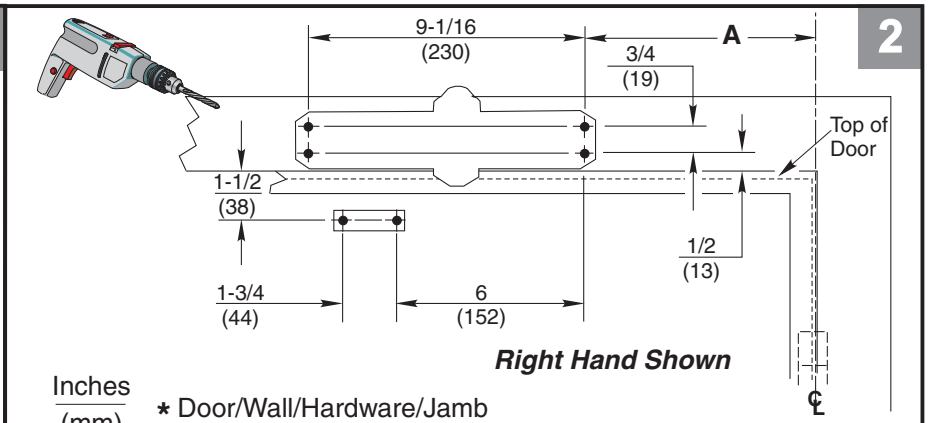
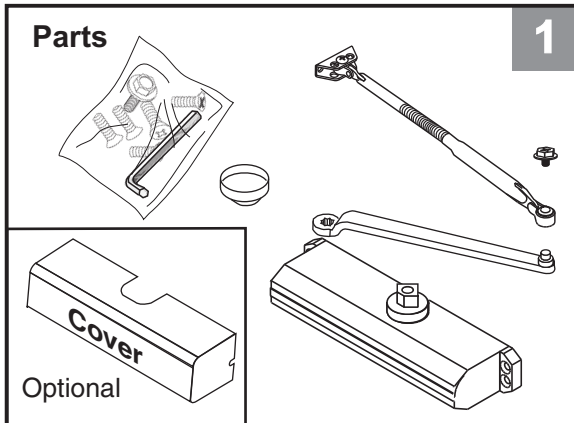

Inches (mm) \* Door/Wall/Hardware/Jamb conditions permitting

Opening	Dimension "A"
To 100°	7-1/2 (191)
101° to 120°	6 (152)
*121° to 180°	3-1/2 (89)

A longer connecting rod is required for reveals greater than 3" (76)

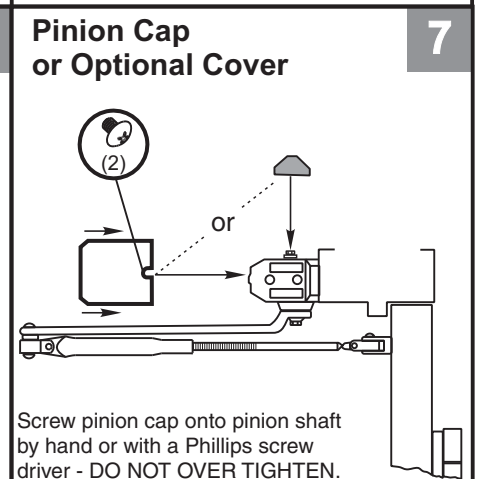
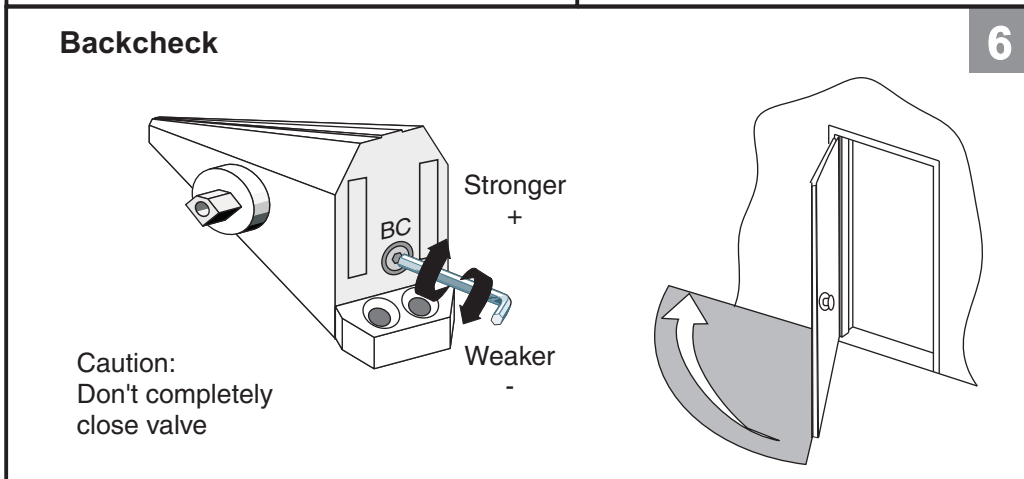
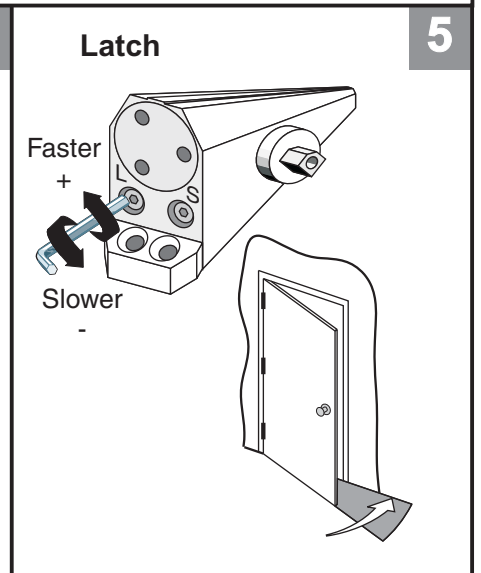
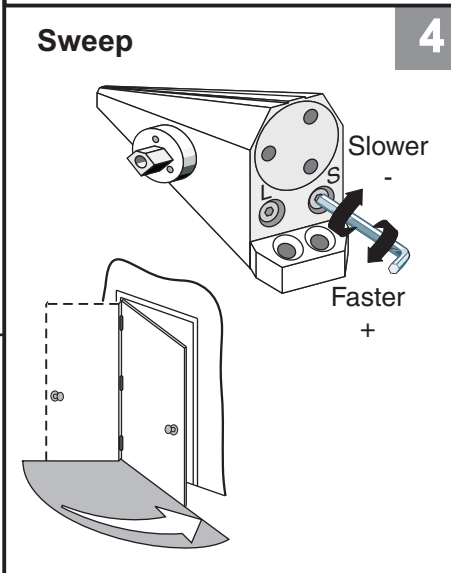
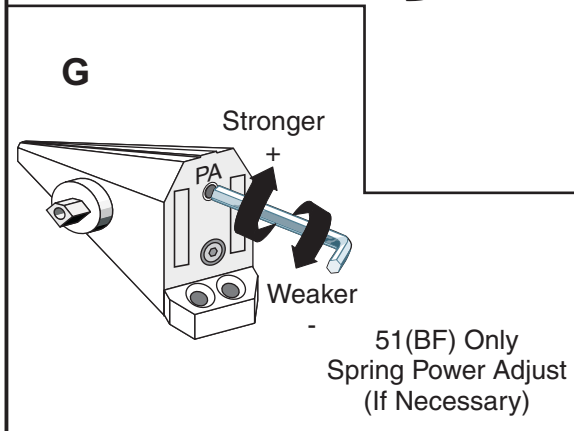
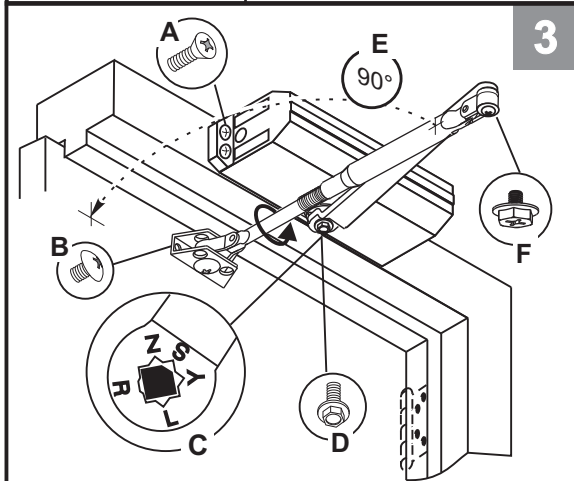
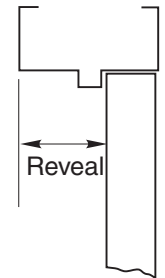

# 50 Series Adjustments Page

80-9350-2502-010 (12-09)

**Yale**

An ASSA ABLOY Group brand

3000 Highway 74 East • Monroe, NC 28112  
Tel: (800)-438-1951 • Fax: (800)-338-0965  
www.yalecommercial.com

Yale® is a registered trademark of Yale Security Inc., an ASSA ABLOY Group company.  
Copyright © 2001, 2009, Yale Security Inc., an ASSA ABLOY Group company. All rights reserved.  
Reproduction in whole or in part without the express written permission of Yale Security Inc. is prohibited.

### Sweep

### Latch

(Use 1/8" Hex Wrench for these Adjustments)

### Backcheck

## Spring Power Adjust 51 (BF) only

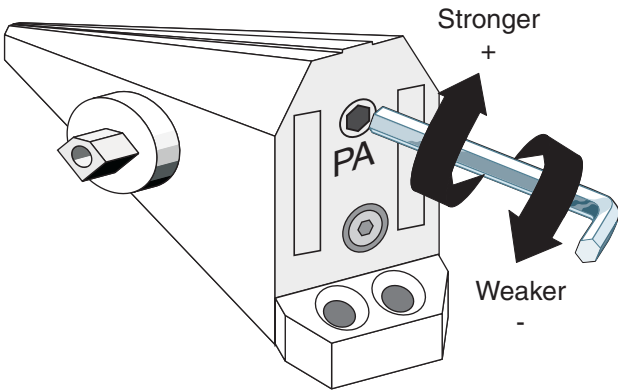

(Use 1/8" Hex Wrench for this Adjustment)

### Adjustment Chart

	DOOR	TYPE OF INST.	*	Number of Turns Required MAXIMUM DOOR SIZE				
				34" (0.85M)	36" (0.90M)	40" (1.00M)	44" (1.10M)	48" (1.20M)
51BF	INTERIOR	Regular Arm Top Jamb	FULL 360° TURNS OF 1/8" POWER ADJUSTMENT SCREW	1	1	2	3	3
		Parallel Arm		2	2	3	4	5
	EXTERIOR	Regular Arm Top Jamb		5	6	8	NOT RECOMMENDED USE 51	
		Parallel Arm		8	9	12		
51	INTERIOR	Regular Arm Top Jamb	FULL 360° TURNS OF 1/8" POWER ADJUSTMENT SCREW	2	4	6	9	11
		Parallel Arm		3	5	7	10	13
	EXTERIOR	Regular Arm Top Jamb		3	5	7	10	13
		Parallel Arm		5	7	10	14	16

\*18 FULL (360°) TURNS MAXIMUM AVAILABLE

= 8 Turns As Shipped

### To identify your model:

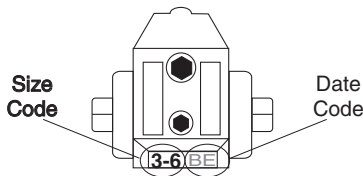

- 2=52BC
- 3=53BC
- 4=54BC
- 5=55BC
- 6=56BC

- 3 - 6=51
- 1 - 4=51BF

### Arm Placement in Shoe

